



Designation: D2384 – 23

Standard Test Methods for Traces of Volatile Chlorides in Butane-Butene Mixtures¹

This standard is issued under the fixed designation D2384; the number immediately following the designation indicates the year of original adoption or, in the case of revision, the year of last revision. A number in parentheses indicates the year of last reapproval. A superscript epsilon (ϵ) indicates an editorial change since the last revision or reapproval.

1. Scope*

1.1 These test methods cover the determination of the total volatile organic chlorides in concentrations from 10 mg/kg to 100 mg/kg in butane-butene mixtures. The amperometric finish is not directly applicable in the presence of other substances that combine with silver ion or oxidize chloride ion in dilute acid solution. Bromides, sulfides, ammonia, tobacco smoke, and more than 25 μg of hydrogen peroxide in the test solution interfere in the spectrophotometric procedure.

1.2 Dissolved sodium chloride is not quantitatively determined using these test methods.

1.3 The values stated in SI units are to be regarded as standard. No other units of measurement are included in this standard.

1.4 *This standard does not purport to address all of the safety concerns, if any, associated with its use. It is the responsibility of the user of this standard to establish appropriate safety, health, and environmental practices and determine the applicability of regulatory limitations prior to use.* Specific warning statements are given in Sections 5, 8, 11, 14, 19, and Annex A1.

1.4.1 *The user is advised to obtain LPG safety training for the safe operation of this test method procedure and related activities.*

1.5 *This international standard was developed in accordance with internationally recognized principles on standardization established in the Decision on Principles for the Development of International Standards, Guides and Recommendations issued by the World Trade Organization Technical Barriers to Trade (TBT) Committee.*

2. Referenced Documents

2.1 *ASTM Standards:*²
[D329 Specification for Acetone](#)

¹ These test methods are under the jurisdiction of ASTM Committee D02 on Petroleum Products, Liquid Fuels, and Lubricants and are the direct responsibility of Subcommittee D02.D0.04 on C4 and C5 Hydrocarbons.

Current edition approved March 1, 2023. Published June 2023. Originally approved in 1965. Last previous edition approved in 2019 as D2384 – 19. DOI: 10.1520/D2384-23.

² For referenced ASTM standards, visit the ASTM website, www.astm.org, or contact ASTM Customer Service at service@astm.org. For *Annual Book of ASTM Standards* volume information, refer to the standard's Document Summary page on the ASTM website.

[D1266 Test Method for Sulfur in Petroleum Products \(Lamp Method\)](#)

3. Summary of Test Methods

3.1 *Combination Test Methods*—Either the lamp or oxy-hydrogen test method may be used for combustion.

NOTE 1—Lamp combustion is readily applicable to multiple testing. Although an oxy-hydrogen burner does not lend itself to multiple testing, it affords much more rapid analysis for a single sample than does the lamp combustion.

3.1.1 *Lamp Combustion*—The sample is burned in an atmosphere of carbon dioxide and oxygen or in purified air; the halogen-containing combustion products are absorbed in dilute sodium carbonate solution.

3.1.2 *Oxy-Hydrogen Combustion*—The sample is burned in an oxy-hydrogen atomizer burner, and the combustion products are absorbed in a dilute solution of sodium carbonate.

3.2 *Finishes*—Either the amperometric titration or spectrophotometric finish may be used for the chloride ion determination.

3.2.1 *Amperometric Titration*—The chloride ion in aqueous solution is titrated amperometrically with standard silver nitrate solution, using a saturated calomel electrode as reference electrode. The diffusion currents are plotted against the corresponding volumes of silver nitrate solution used; the end point is taken as the intersection of the two straight-line portions of the curve.

3.2.2 *Spectrophotometric Finish*—Chloride ion in the absorber solution is determined by reaction with mercuric thiocyanate to release thiocyanate, which forms a reddish orange complex with Fe^{+++} . The intensity of the color is measured at 460 nm with a spectrophotometer or filter photometer.

4. Significance and Use

4.1 These test methods are used to determine trace amounts of volatile chlorides in butane-butene mixtures. Such information is valuable in cases where chloride is deleterious in the use of this product; also, chloride contributes to corrosion problems in processing units in instances where further processing of this material is involved.

5. Purity of Reagents

5.1 *Purity of Reagents*—Reagent grade chemicals shall be used in all tests. Unless otherwise indicated, it is intended that

*A Summary of Changes section appears at the end of this standard

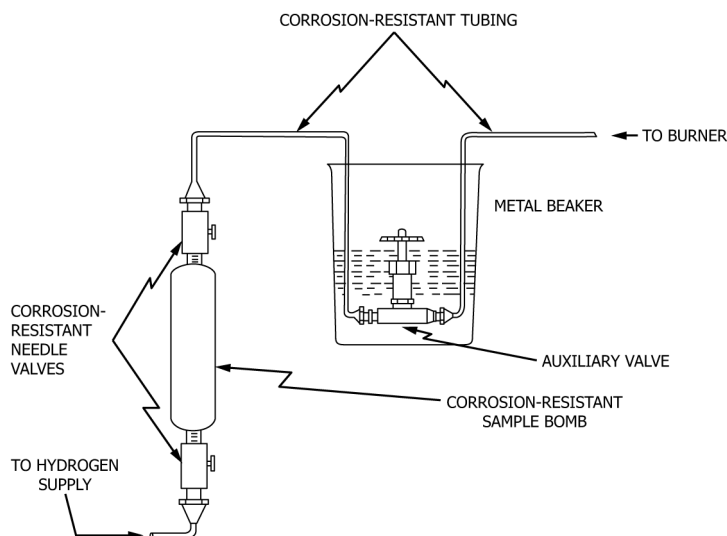

FIG. 1 Diagrammatic Sketch of Butane-Butene Heat Exchange System

all reagents shall conform to the specifications of the Committee on Analytical Reagents of the American Chemical Society, where such specifications are available.³ Other grades may be used, provided it is first ascertained that the reagent is of sufficiently high purity to permit its use without lessening the accuracy of the determination.

5.2 References to water shall be understood to mean chloride-free distilled or deionized water.

5.3 (**Warning**—In view of the common occurrence of chloride in reagents and laboratory air, special care must be taken during preparation and storage of reagents to avoid contamination. They should be isolated from other reagents and used solely for these methods. A blank determination must be performed each time a reagent is changed to ensure that it is not contaminated with chloride.

It is also imperative that all glassware used in this determination be cleaned thoroughly and rinsed four times with *chloride-free* distilled or deionized water. Utmost caution must be taken during the analysis to prevent contamination from chlorides.)

6. Sampling

6.1 Steam and dry a 10 mL to 25 mL corrosion-resistant metal sample cylinder having a 450 psi (3100 kPa) working pressure and equipped with a needle valve outlet at each end.

6.2 Pressure the prepared cylinder with dry hydrogen to 20 psig (137.5 kPa gauge) to afford a gas cushion preventing rupture due to liquid expansion on increase of temperature.

6.3 Obtain a liquid sample from the purged sample line, filling the upright cylinder through the bottom needle valve, keeping the top valve closed. Do not purge the sample cylinder.

³ ACS Reagent Chemicals, Specifications and Procedures for Reagents and Standard-Grade Reference Materials, American Chemical Society, Washington, DC. For suggestions on the testing of reagents not listed by the American Chemical Society, see *Analar Standards for Laboratory Chemicals*, BDH Ltd., Poole, Dorset, U.K., and the *United States Pharmacopoeia and National Formulary*, U.S. Pharmacopoeial Convention, Inc. (USPC), Rockville, MD.

LAMP COMBUSTION TEST METHOD

7. Apparatus

7.1 *ASTM Lamp Assembly*—Use the apparatus specified in Test Method **D1266**, including the liquefied petroleum gas burner assembly.

8. Reagents

8.1 Use the necessary reagents and materials specified in Test Method **D1266**, in addition to the absorber solution as described in 8.3.

8.2 *Hydrogen* (**Warning**—Extremely flammable (liquefied) gas under pressure. See Annex **A1.1**.)

8.3 *Sodium Carbonate Absorbent (2 g/L)*—Dissolve 2.0 g of anhydrous sodium carbonate (Na_2CO_3) in water and dilute to a litre with water.

9. Procedure

9.1 Prepare the combustion apparatus as described in Section 7 of Test Method **D1266**, Preparation of Apparatus, using 35 mL of Na_2CO_3 solution to charge the absorber.

9.2 Weigh the vessel containing the sample to the nearest 0.1 g. Support the sample vessel in an upright position so that the sample is burned from the gaseous phase. Connect the sample vessel to the auxiliary corrosion-resistant regulating valve by means of corrosion-resistant metal tubing (**Fig. 1**) (**Note 2**). Connect the bottom valve of the sample vessel to the regulated hydrogen supply. By means of short lengths of chloride-free rubber tubing, connect the auxiliary valve outlet to the side inlet of the gas burner and the lower inlet of the gas burner (Test Method **D1266**, Annex A3, Apparatus Detail, **Fig. 5**) to the burner manifold.

NOTE 2—For steady burning, it may be necessary to surround the auxiliary valve with a heat-exchanger system. A convenient means is winding insulated heating wire, having a resistance of 40 Ω to 60 Ω , around the auxiliary valve and connecting it to a suitable rheostat. Another means is to place the regulating valve in a suitable metal beaker and cover the valve body with water maintained at 60 °C to 80 °C.

9.3 Open the valve on the sample vessel; then open the auxiliary valve to allow a small stream of vapor to escape. Quickly light the burner. Adjust the flow of CO₂-O₂ mixture and the sample so that the flame is approximately 35 mm high and clear blue in color; this color is reached just beyond the point at which a yellow color shows at the tip of the flame. Insert the burner into the chimney and readjust the flame if necessary. When the sample has burned almost to completion, open the valve on the bottom of the sample vessel and flush the residual sample from the cylinder chamber by passing hydrogen through the bottom valve for several minutes.

9.4 When all of the residual material has been flushed from the sample vessel, turn off the hydrogen and close the valves on the sample vessel. Disconnect the hydrogen flushing line and the line to the heated auxiliary valve and weigh the sample vessel to the nearest 0.1 g. Draw the combustion atmosphere through one absorber of a set to serve as a blank on the purity of this atmosphere. Rinse the chimneys and spray traps with water and add the rinsings to the absorbers.

9.5 Proceed in accordance with either Section 16 or 21.

**OXY-HYDROGEN COMBUSTION TEST METHOD—
ALTERNATIVE TEST METHOD**

10. Apparatus

10.1 *Oxy-Hydrogen Burner*⁴—A flow diagram of a typical apparatus is shown in Fig. 2. The apparatus shall consist of three parts: atomizer-burner, combustion chamber, and receiver with spray trap. A blowout safety port in the combustion chamber is desirable. The remainder of the apparatus shall consist of a steel support stand with the necessary needle valves and flow meters for precise control of air, oxygen, hydrogen, and vacuum.

10.2 *Vacuum Pump*, having a capacity of at least 1200 L/h, and protected from corrosive fumes by suitable traps.

11. Reagents and Materials

11.1 *Hydrogen (Warning—Extremely flammable (liquefied) gas under pressure. See Annex A1.1.)*

11.2 *Oxygen (Warning—Oxygen vigorously accelerates combustion. See Annex A1.2.)*

11.3 *Sodium Carbonate, Absorbent (2 g/L)—See 8.3.*

12. Procedure

12.1 Follow the manufacturer's instructions for preparing and operating the apparatus. Place 50 mL of the Na₂CO₃ absorbent in the absorber. Burn all of the sample from the gas phase of the cylinder (Fig. 1). (**Warning—Extremely flammable (liquefied) gas under pressure. See Annex A1.1.**) Flush the residual gases from the cylinder chamber by passing

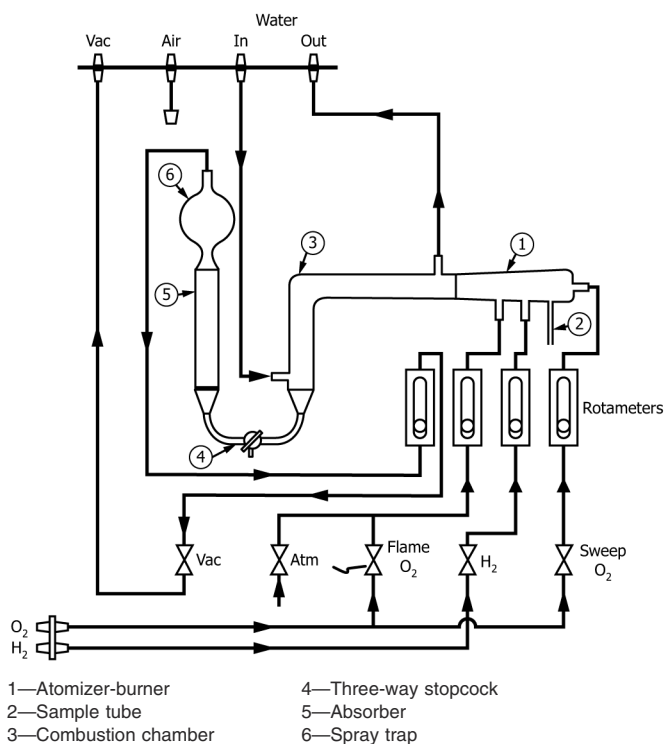

FIG. 2 Flow Diagram of a Typical Oxy-Hydrogen Combustion Apparatus

hydrogen through the bottom valve for several minutes, burning the flushed gases.)

12.2 When combustion is completed, rinse all water-cooled portions of the apparatus and the spray trap with a spray of water. Collect all rinsings in the absorbent.

12.3 Proceed in accordance with either Section 16 or 21.

12.4 Prepare a blank by placing 50 mL of the Na₂CO₃ absorbent in the absorber. Operate the apparatus for the same period of time, under the same conditions that were used for the combustion of the sample, but without a sample and the sample inlet closed to the atmosphere. Burn approximately the same volume of hydrogen as was used to flush the same cylinder. When combustion of the hydrogen is complete, rinse all water-cooled portions of the apparatus and the spray trap with a spray of water. Collect all rinsings in the absorbent. Proceed as in 12.3.

AMPEROMETRIC TITRATION FINISH

13. Apparatus

13.1 *Potentiometer-Galvanometer Assembly*, capable of applying a cell potential up to 3 V with an accuracy of 1 % of full scale, and capable of indicating the cell current by means of a galvanometer having a sensitivity of 0.005 μA/mm to 0.008 μA/mm scale division. A multiposition galvanometer shunt for adjustment of current measurement sensitivity should also be provided; shunt ratios to give sensitivities of approximately 0.05 μA/mm to 0.08 μA/mm, and 0.10 μA/mm to 0.16 μA/mm should be included.

⁴ The Wickbold Burner Apparatus obtainable from the Atlas Instrument Co., 8902 E. 11th St., Tulsa, OK, or the Richfield Burner Apparatus obtainable from the Greiner Glass Blowing Laboratories, 3604 E. Medford St., Los Angeles, CA 90034, has been found suitable for this purpose. If you are aware of alternative suppliers, please provide this information to ASTM International Headquarters. Your comments will receive careful consideration at a meeting of the responsible technical committee, which you may attend.